

Unit	"A" ± 1/64	"B" Ref. Only
730	6.310	6-3/4
732	7.469	7-1/16
738	7.25	7-3/4
752	8.44	9-1/16
760	9.28	10

Figure No. 1

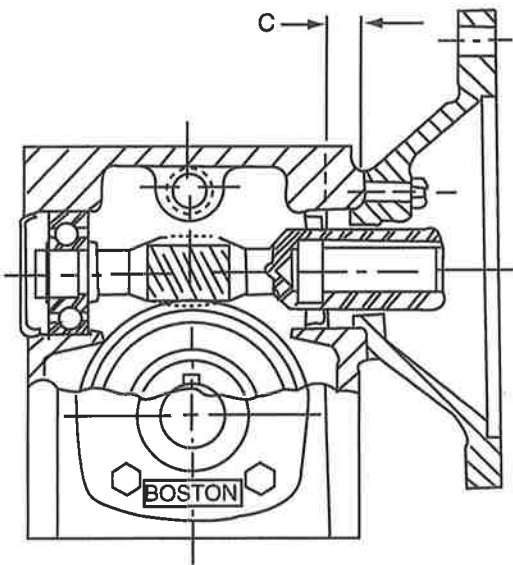

Unit Size	"C" Dimension
F710/FW713	5/16
FW718	
F713/FW721	3/8
FW726	
F715	3/8
F718/FW732	3/8
F721/FW738	3/8
F724	3/8
F726	3/8
F730	3/8
F732	5/8
F738	5/8

Figure No. 2

Note: "C" Dimensions shown are original oil seal locations. When seal is replaced add or subtract 1/16th of an inch to dimension shown. This will allow seal to wear on a new surface for extended life.

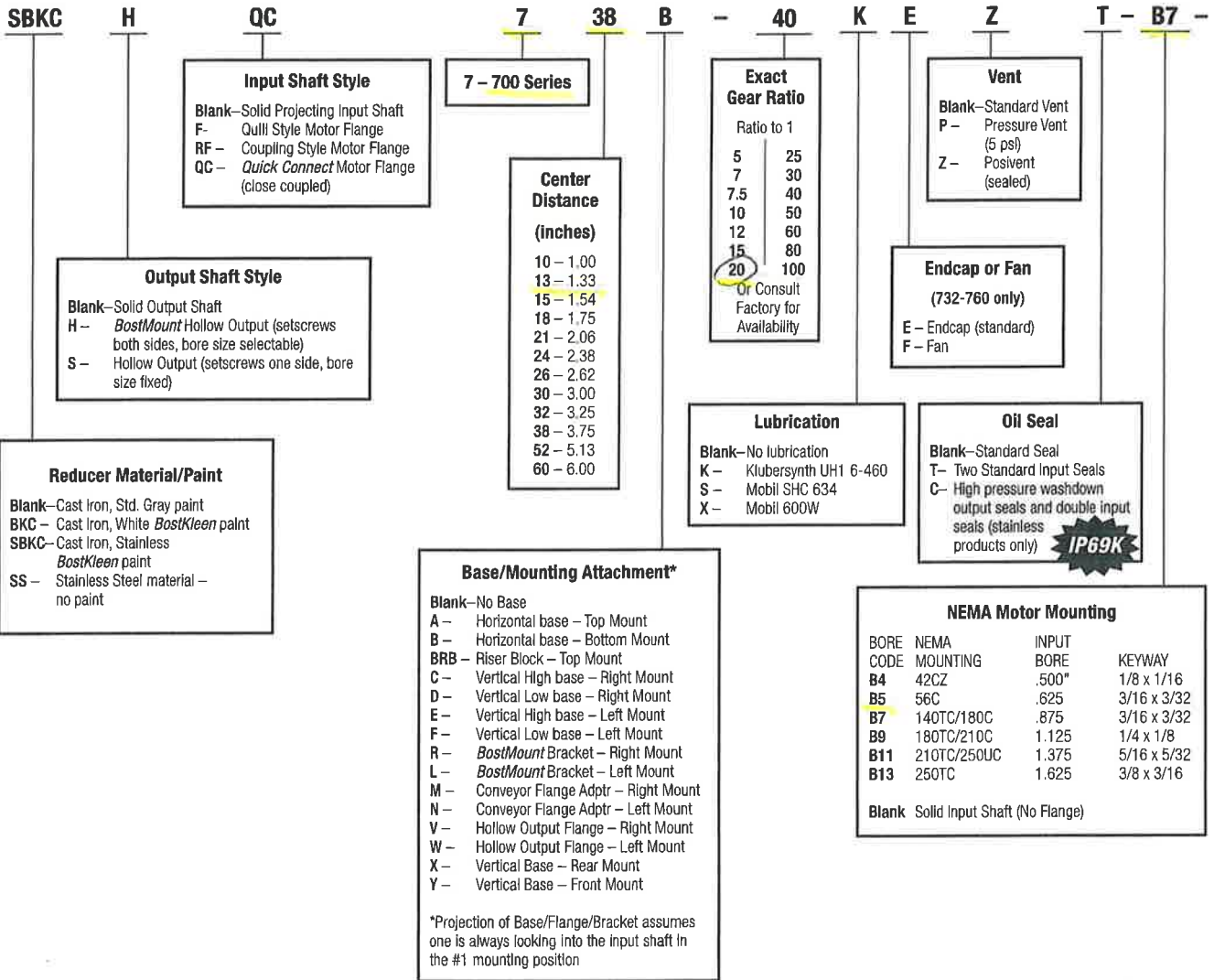

HS 1

P24

BestMount Output Bore Code

For H Series Only Specified in 1/16" increments.

Example: 1 1/4" = P20

5/8 - P10	1-1/2 - P24
3/4 - P12	1-5/8 - P26
7/8 - P14	1-11/16 - P27
15/16 - P15	1-3/4 - P28
1 - P16	1-7/8 - P30
1-1/16 - P17	1-15/16 - P31
1-1/8 - P18	2 - P32
1-3/16 - P19	2-1/8 - P34
1-1/4 - P20	2-3/16 - P35
1-5/16 - P21	2-1/4 - P36
1-3/8 - P22	2-7/16 - P39
1-7/16 - P23	3-7/16 - P55

See catalog for availability by center distance. Consult Factory for Metric Bores

Mounting Positions

Blank - No Lubrication Supplied

For Factory Prelubrication Indicate Mounting Position

- 1 - Standard Mounting (Worm over)
- 2-6 - Refer to Mounting Positions In Catalog

Output Shaft

(When facing Input and worm on top)

- G - Carbon Steel Output Projection - Left
- H - Carbon Steel Double Output Projection
- J - Carbon Steel Output Projection - Right
- GS - Stainless Output Projection - Left
- HS - Stainless Double Output Projection
- JS - Stainless Output Projection - Right

Clutch/Brake

CMBA140TR-6

Common C-Face Brakes Installed

115/230 VAC 60hz	Ft-Lb	Bore Code
CMBA56R-3	3	B5
CMBA56R-6	6	B5
CMBA140TR-6	6	B7
208-230/460 VAC 60hz	Ft-Lb	Bore Code
CMBA56U-3	3	B5
CMBA56U-6	6	B5
CMBA140TU-6	6	B7

Other sizes available. See catalog P-1485-BG.

Motor

HUTF-IDB - 3

Motor Conduit box Orientation
(When looking at fan end of motor and gearbox is in mounting position #1)

- 0 - 12 O'clock
- 3 - 3 O'clock (standard for G & H shaft assemblies)
- 6 - 6 O'clock
- 9 - 9 O'clock (standard for J shaft assemblies)

Common C-Face Motors Installed

HP Rating	Bore Code	AC Voltage	
		115/208-230-1-60	208-230/460-3-60
1/4 HP	B5	DRTFB	DUTFB
1/3 HP	B5	ERTFB	EUTFB
1/2 HP	B5	FRTFB	FUTFB
	B5		FUT-SS
	B5		FUTF-IDB
3/4 HP	B5	GRTFB	GUTFB
	B5		GUT-SS
	B5		GUTF-IDB
1 HP	B5	HRTF-5/8B	HUTF5/8B
	B5		HUT5/8-SS
	B5		HUTF5/8-IDB
	B7	HUTFB	
	B7	HUT-SS	
1.5 HP	B7		HUTF-IDB
	B7		JUTFB
	B7		JUTF-SS
2 HP	B7		JUTF-IDB
	B5		KUTF5/8B
	B7		KUTFB
	B7		KUTF-SS
3 HP	B7		KUTF-IDB
	B9		LUTFB
	B9		LUTF-SS
5 HP	B9		LUTF-IDB
	B9		MUTFB

Other motors available, please see catalog P-1485-BG.

- T - Totally enclosed non-ventilated
- TF - Totally enclosed fan cooled
- SS - Stainless
- IDB - Inverter Duty (10:1 turn down constant torque)
- B5 - 56C
- B7 - 140TC
- B9 - 180TC